

No. 730,307.

PATENTED JUNE 9, 1903.

F. E. STANLEY.
STEAM MOTOR VEHICLE.
APPLICATION FILED NOV. 5, 1902.

NO MODEL.

3 SHEETS—SHEET 1.

Fig. 1.

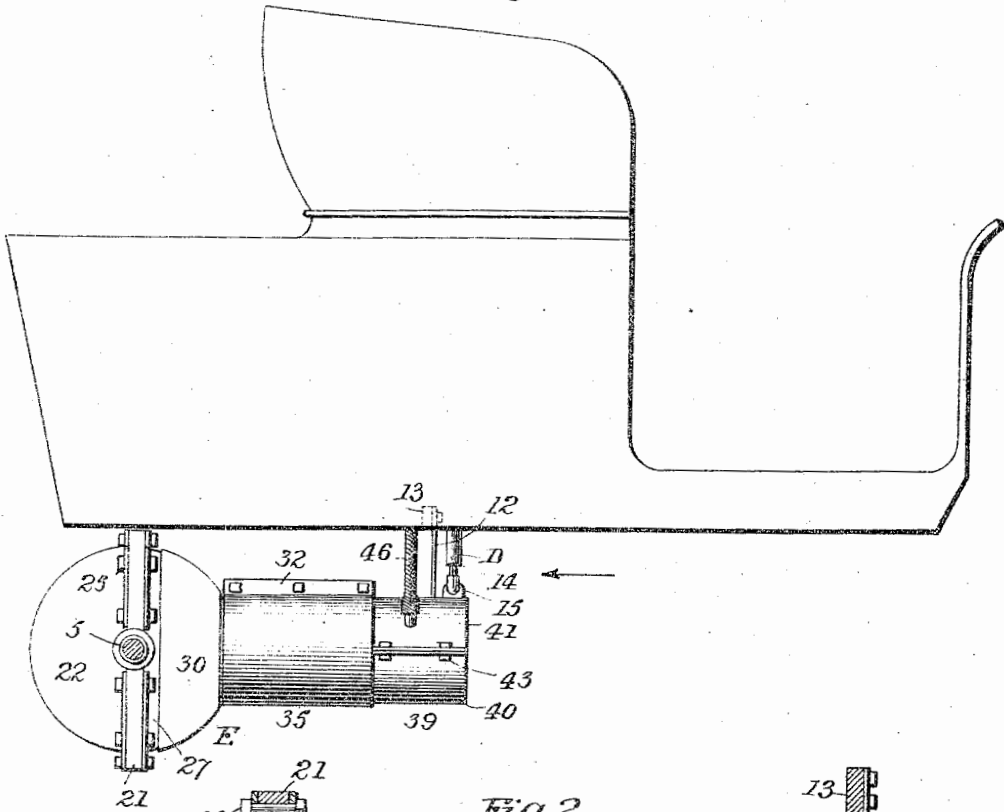
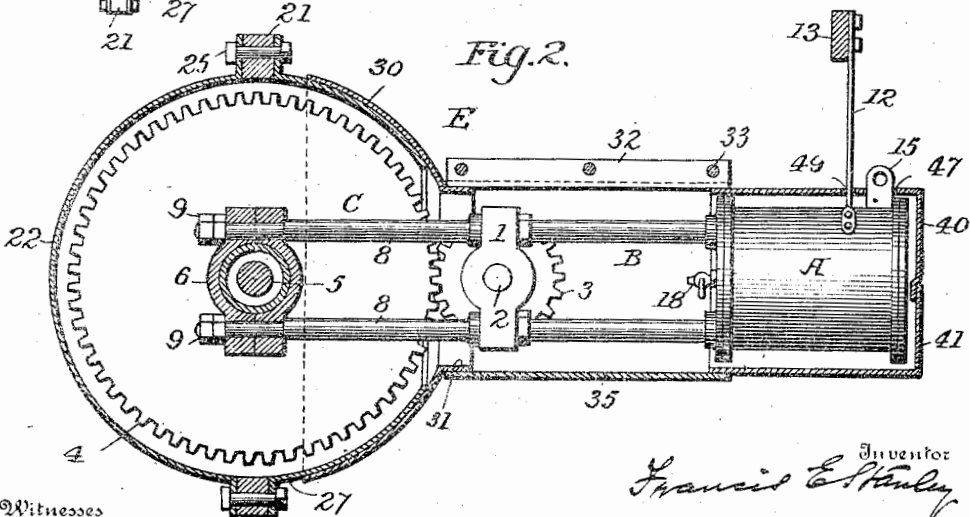

Fig. 2.



Witnesses
J. H. Hinkel
A. M. Gillman

Inventor
Francis E. Stanley
 By *John Freeman*
 Attorneys

No. 730,307.

PATENTED JUNE 9, 1903.

F. E. STANLEY.
STEAM MOTOR VEHICLE.
APPLICATION FILED NOV. 6, 1902.

NO MODEL.

3 SHEETS—SHEET 2.

Fig. 3.

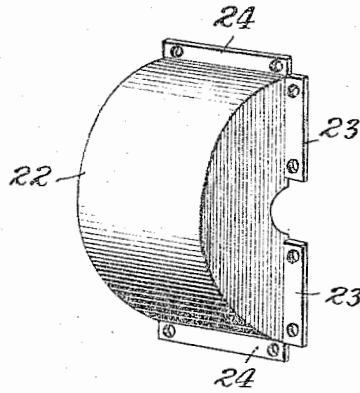

Fig. 4.

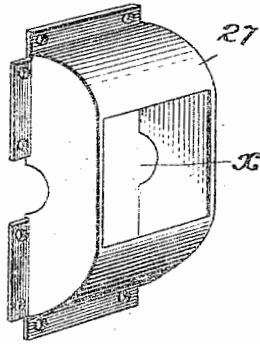

Fig. 5.

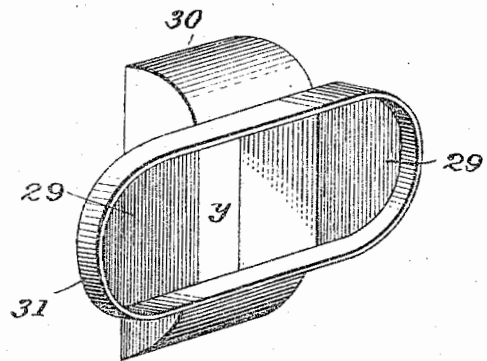
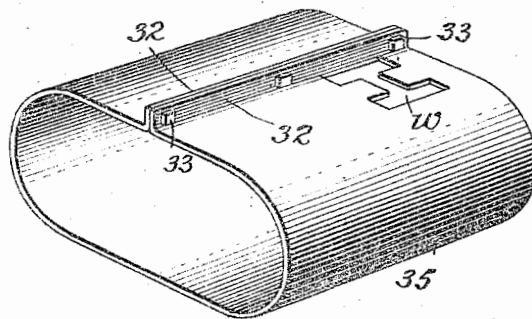

Fig. 6.



Inventor

Francis E. Stanley

By *Lucas Freeman*
Attorneys

Witnesses

J. Hinkel
Wm. Gillman, Jr.

F. E. STANLEY.
STEAM MOTOR VEHICLE.
APPLICATION FILED NOV. 5, 1902.

NO MODEL.

3 SHEETS—SHEET 3

Fig. 7.

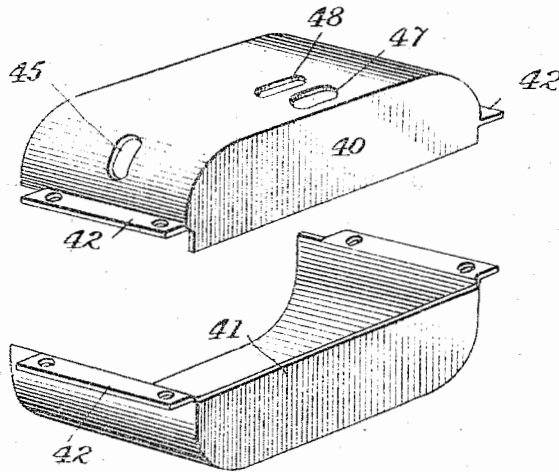

Fig. 8.

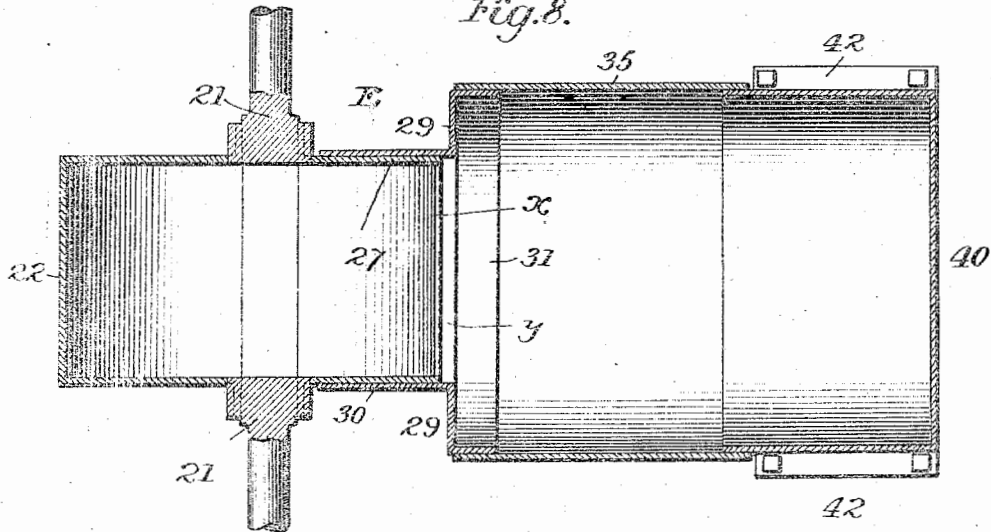
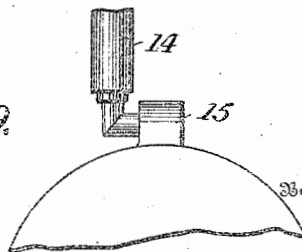

FIG. 9.



Witnesses

J. Hinkel
Wm. Gillman, Jr.

Inventor

Francis E. Stanley

John A. Freeman
Attorney

UNITED STATES PATENT OFFICE.

FRANCIS E. STANLEY, OF NEWTON, MASSACHUSETTS.

STEAM MOTOR-VEHICLE.

SPECIFICATION forming part of Letters Patent No. 730,307, dated June 9, 1903.

Application filed November 5, 1902. Serial No. 130,147. (No model.)

To all whom it may concern:

Be it known that I, FRANCIS E. STANLEY, a citizen of the United States, residing at Newton, in the county of Middlesex and State of Massachusetts, have invented certain new and useful Improvements in Steam Motor-Vehicles, of which the following is a specification.

My invention relates to motor-vehicles, and especially to those driven by steam; and it consists in the arrangement of the engine in relation to the compensating gear and body of the vehicle and to means for protecting and oiling the parts, as fully set forth hereinafter and as illustrated in the accompanying drawings, in which—

Figure 1 illustrates in general outline and part section a motor-vehicle and in side elevation the parts embodying my invention; Fig. 2, an enlarged view in section through the casing. Figs. 3, 4, 5, 6, and 7 are perspective views of parts of the casing. Fig. 8 is a sectional plan showing the casing parts as arranged in respect to the yoke of the axle. Fig. 9 is a detailed view looking in the direction of the arrow, Fig. 1.

The engine A, of any suitable construction, has a frame B, provided with bearings 1 for the crank-axle 2, on which is a gear 3, engaging the gear 4 of the compensating gearing connected with the driving-axle 5 of the vehicle. Upon the axle 5, or preferably on the ball-casing thereof, at each side of the gear 4, swivels a ring-bearing 6, constituting part of an extension-frame C, constituting a prolongation of the engine-frame. As shown, there are parallel rods 8 8, extending between the bearings 1 and 6, each of the latter in two half-sections, with ears through which pass the rods 8, the latter having shoulders between which and nuts 9 the ears are confined. This arrangement permits the engine-frame and its engine to swing around the axis of the driving-axle to maintain the relation of the gears 3 4 in all positions of the parts. At the opposite end the engine is suitably and flexibly suspended from the body of the vehicle, as by a steel band 12, bolted to the engine and to a cross-piece 13 of the vehicle.

Steam connection between the valve-casing of the engine and the boiler is secured by a flexible conduit D. As shown, Fig. 9, the supply-pipe 14 has a lateral branch turning

in the socket of a boss 15 on the engine. This permits the body of the vehicle to rise and fall and swing forward and back, while maintaining a perfect steam connection.

To protect the engine and compensating gear from dust and maintain the parts properly oiled, they are inclosed in a casing E, to which a limited supply of steam is admitted and in which it is maintained.

While the casing E may be constructed in any suitable way, a preferable construction is shown, in which the casing is in sections to permit of the swinging movement of the engine and ready access to the parts.

The compensating gear is within a yoke 21 of the rear axle, and to the rear of this is bolted the section 22 of the casing, said section being nearly semicylindrical, with side and end flanges 23 24, perforated for the passage of the bolts 25. In front of the yoke is bolted a section 27, like the section 22, but truncated to form an opening x . To the outer face of the section 27 is fitted a corresponding truncated section 30 with a forward opening y . From each side of the opening y , Fig. 5, extends laterally a wing 29, and around the edges of the wings and above and below the opening y extends a flange 31. The section 30 is not so deep as the section 27, on which it fits, so that the section 30 can slide on the face of the inner section above the axis of the axle 5 as a center. Within the flange 31 fits the section 35 of the casing, the same of one flexible sheet of metal bent to form a hollow flattened cylinder with edge flanges 32 32, secured together by bolts 33. The flexibility of this section permits its ready application in and removal from position. The sections 22 27 30 inclose the compensating gear, the section 35 the working parts of the engine and supporting-frame, and a separate section 39 incloses the cylinder. The section 39 consists of two parts 40 41, which together correspond to the shape of the section 35, of which they are a prolongation, each part closed at the outer end and with flanges 42 perforated for the passage of bolts 43.

It will be understood that the flanges 32 of the section 35 are cut away to permit the end of that section to enter the flange 31 and that the flanges 42 of the section 39 are cut away to permit the end of the section 39 to enter

the section 35. In the section 35 are suitable slots *w* for the passage of the levers, which must be operated to regulate the engine, while the section 39 has an opening 45 for the exhaust-pipe 46, of rubber, another opening 48 for the suspension-strip 12, and another, 47, for the boss 15.

Without limiting myself to the precise construction shown, I claim—

10 1. The combination with the axle, compensating gear and engine of a motor-vehicle, of a frame pivoted to swing about the axis of the axle and consisting of rods extending between the axle and the engine-frame, and constituting a continuation of the latter, substantially as set forth.

20 2. The combination with the engine, axle and compensating gear, of a yoke inclosing said gear, a casing having a removable cap-section 22 secured to said yoke, a truncated section 27 secured at the opposite side of the yoke, and a casing inclosing the engine and frame and provided with a section 30 fitted to slide on the section 27, substantially as set forth.

25 3. A casing for the engine and gears of a motor-vehicle provided with truncated sections 27, 30, one fitted to slide on the other

and with wings 29 and a flange 31 for receiving another section of the casing, substantially as set forth.

4. The combination with the sections of a casing fitted to inclose the cylinders and gear, of an intermediate section 35 consisting of a single flanged flexible sheet, substantially as set forth.

5. The combination with the section of a casing inclosing the working parts of an engine, of a section inclosing the cylinder and consisting of two flanged parts 40, 41 closed at the ends, substantially as set forth.

6. The combination with the axle, compensating gear and body of a motor-vehicle, of an engine hung to swing about the axle and a casing in separable parts inclosing the engine and gears, one of the parts swinging on the other about the axis of the axle, substantially as set forth.

In testimony whereof I have signed my name to this specification in the presence of two subscribing witnesses.

FRANCIS E. STANLEY.

Witnesses:

J. W. BACON,
MARGARET L. HART.